

Full-Industrial Embroidery Machine
With Standard Color LCD Control Panel
With Standard Software for LAN Connection



HCD 1501-40

Computerized Single Head Embroidery Machine

 HAPPY Industrial Corporation

JAPAN

HCD 1501-40

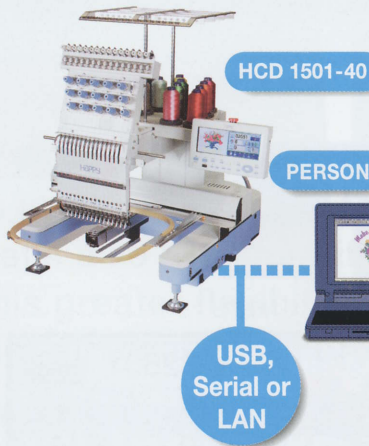

Link Soft HAPPY Link SOFTWARE

Attached "Link soft" allows you to operate most of the Machine function from PC.



PERSONAL COMPUTER

COLOR LCD CONTROL PANEL



SLOT IN!

MEMORY CARD



CARD ADAPTER



The included HAPPY Link software lets you manage & setup your machines, your design library, and connect between your PC and HAPPY machines! A great added value.

STANDARD FEATURES AND FUNCTIONS

MACHINE MEMORY 1,000,000 stitch
HELP MENU
DESIGN CONVERT
DESIGN ROTATE
DESIGN EDITING
DESIGN SCALING

AUTOMATIC FORMAT IDENTIFICATION
AUTOMATIC COLOR CHANGE
AUTO ORIGIN
FRAME TRACE
FRAME OFFSET
FRAME OUT

STITCH SWEEPING
REPEAT SEWING
WIDTH ADJUSTMENT
BATCH SEWING

STANDARD EQUIPMENT

HAPPY LINK SOFTWARE(CD)
PC CONNECTION: SERIAL, USB AND LAN
(INCLUDES USB CABLE)
ROTARY TYPE THREAD SENSORS

BUILT IN MEMORY CARD SLOT
(PC-ATA-STANDARDS)
AUTOMATIC THREAD TRIMMER

OPTIONAL EQUIPMENT

ADDITIONAL MEMORY(UP TO 2,000,000)
FLOPPY DISK DRIVE
NEEDLE SENSOR
CAP FRAME

BOBBIN WINDER
BORDER FRAME
FLAT TABLE

SPECIFICATIONS

MODEL	Embroidery Area	Cap Frame Wide	Cap Frame Low-Profile	Largest Tubular Frame Size	Number of Needles	Stitch Length(mm)	Max Speed (rpm)	Memory (Stitch)	Power Supply	Power Consumption	Frequency	Weight
HCD-1501-40	520×400mm	80 × 360mm	75 × 180mm	420 × 440mm	15	0.1~12.7mm	1,200	1,000,000 up to 2,000,000	AC100~120V	260W	50/60Hz	106 kg 233 lbs
	20.5×15.7inch	3.2×14.2inch	3.0×7.1inch	16.5×17.3inch					AC200~230V			

MODEL	Dimensions						
	L	W	H	A	B	C	
HCD-1501-40	762	782	871	885	580	811	(mm)
	30.2	30.8	34.3	34.8	22.8	31.9	(inch)

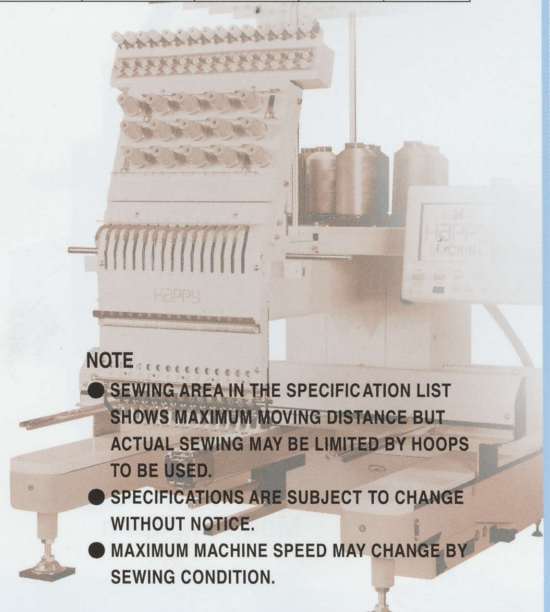
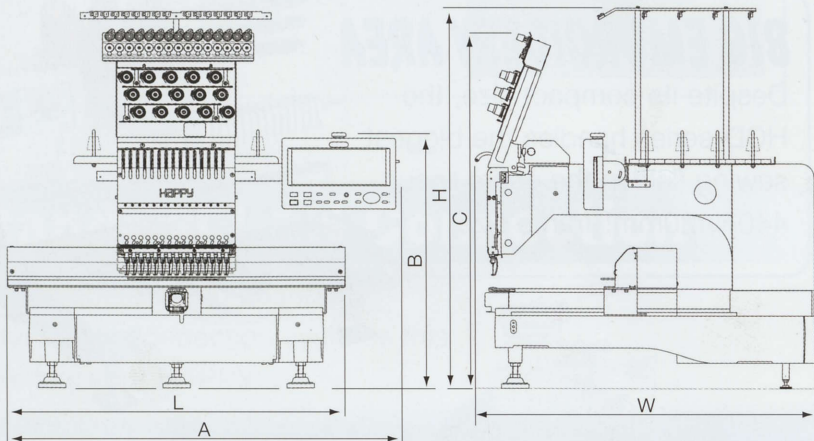

NOTE

- SEWING AREA IN THE SPECIFICATION LIST SHOWS MAXIMUM MOVING DISTANCE BUT ACTUAL SEWING MAY BE LIMITED BY HOOPS TO BE USED.
- SPECIFICATIONS ARE SUBJECT TO CHANGE WITHOUT NOTICE.
- MAXIMUM MACHINE SPEED MAY CHANGE BY SEWING CONDITION.

Manufactured by :

HAPPY Industrial Corporation

TOKYO OFFICE 9-5, Taito 2-chome Taito-ku, Tokyo, Japan
phone: +81-3-3834-0711 fax: +81-3-3835-8917
E-mail: emb-info@happy-ind.co.jp

Distributed by :